

Solenoid valves for gas VG

TECHNICAL INFORMATION

- Safety valves for gas
- Quick or slow opening with adjustable start gas rate
- Flow rate can be restricted
- Suitable for high-duty cycling
- Robust design for a long service life
- Suitable for hydrogen



Contents

Contents	2	8 Technical data	17
1 Application	3	9 Dimensions	18
1.1 Application examples	4	9.1 VG 6 to 15/10	18
2 Certification	5	9.2 VG 15 to 40/32	19
2.1 Certificate download	5	9.3 VG 40 to 65	20
2.2 Declaration of conformity	5	10 Converting units	21
2.3 UKCA certified	5	11 Maintenance cycles	22
2.4 AGA approved	5	For more information	23
2.5 Eurasian Customs Union	5		
2.6 REACH Regulation	5		
2.7 China RoHS	5		
3 Function	6		
3.1 Gas solenoid valve VG..N, quick opening	6		
3.2 Gas solenoid valve VG..L, slow opening	7		
4 Flow rate	8		
4.1 Valves for low inlet pressures, $p_U < 1$ bar	8		
4.2 Valves for higher inlet pressures, $p_U > 1$ bar	10		
4.3 Calculating the nominal size	11		
5 Selection	12		
5.1 ProFi	12		
5.2 VG 6–15/10	12		
5.2.1 Type code	12		
5.3 VG 10/15–65	13		
5.3.1 Type code	14		
6 Project planning information	15		
6.1 Installation	15		
6.2 Electrical connection	15		
6.3 Hydrogen	15		
7 Accessories	16		
7.1 Pressure test nipples	16		
7.2 Plug with socket	16		

1 Application



VG 6 to 15/10



VG..R..N, quick opening



VG..R..L, slow opening



VG..F..N, quick opening

Robust gas solenoid valves VG for safeguarding and controlling the air and gas supply to gas burners and gas appliances. For heavy-duty use in gas control and safety systems in industrial heat generation.

1.1 Application examples



Metallurgical industry: forging furnace



Ceramics industry: intermittent shuttle kiln

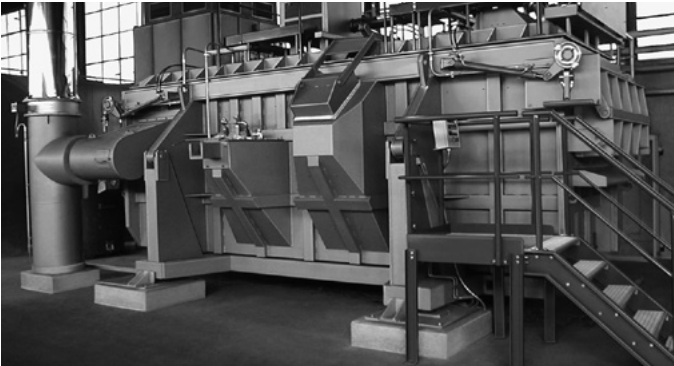

Aluminium industry: smelting furnace

2 Certification

2.1 Certificate download

Certificates – see www.docuthek.com

2.2 Declaration of conformity



We, the manufacturer, hereby declare that the product VG with product ID No. CE-0063BL1553 complies with the requirements of the listed Directives and Standards.

Directives:

- 2014/35/EU – LVD
- 2014/30/EU – EMC
- 2011/65/EU – RoHS II
- 2015/863/EU – RoHS III

Regulation:

- (EU) 2016/426 – GAR

Standards:

- EN 161:2011+A3:2013

The relevant product corresponds to the tested type sample.

The production is subject to the surveillance procedure pursuant to Regulation (EU) 2016/426 Annex III paragraph 3.

Elster GmbH

2.3 UKCA certified



Gas Appliances (Product Safety and Metrology etc. (Amendment etc.) (EU Exit) Regulations 2019)

BS EN 161:2011+A3:2013

2.4 AGA approved



Australian Gas Association, Approval No.: 3968.

2.5 Eurasian Customs Union



The products VG meet the technical specifications of the Eurasian Customs Union.

2.6 REACH Regulation

The device contains substances of very high concern which are listed in the Candidate List of the European REACH Regulation No. 1907/2006. See Reach list HTS at www.docuthek.com.

2.7 China RoHS

Directive on the restriction of the use of hazardous substances (RoHS) in China. Scan of the Disclosure Table China RoHS2, see certificates at www.docuthek.com.

3 Function

3.1 Gas solenoid valve VG..N, quick opening

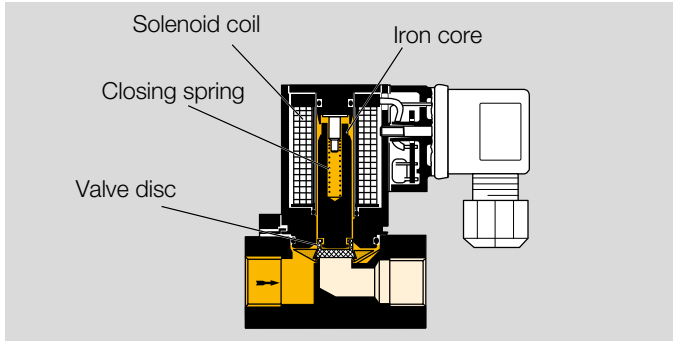

VG 6-15/10..R..N

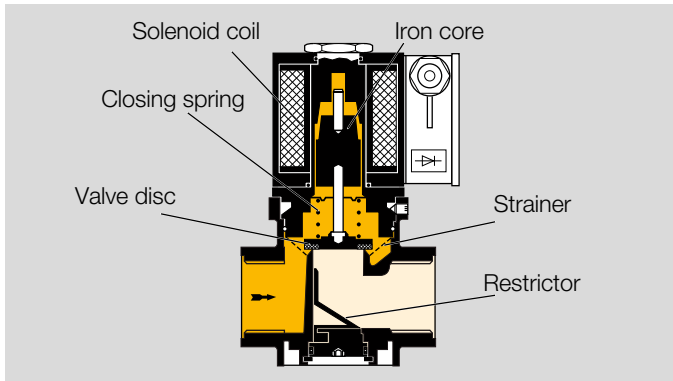

VG 15-40/32..R..N

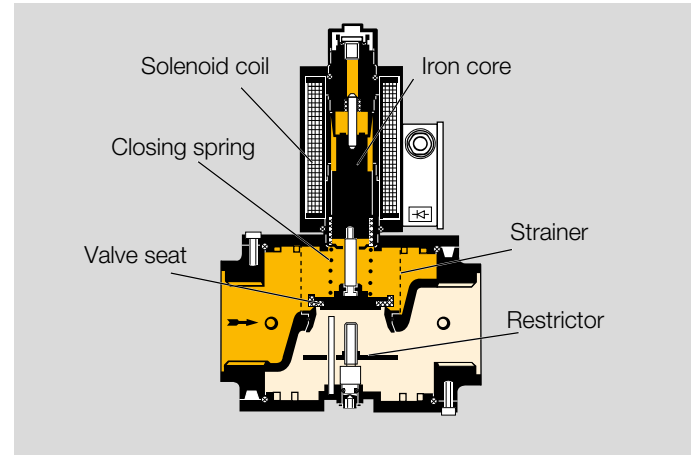

VG 40-65..R..N

The gas solenoid valve VG is closed when de-energized.

Opening: the applied AC voltage is rectified and generates a powerful magnetic field in the solenoid coil. The magnetic field attracts the iron core and lifts the valve plate from the valve seat, acting against the effective inlet pressure and the closing spring force. The gas solenoid valve VG opens and the gas supply is released.

Closing: when the voltage is disconnected, the magnetic field collapses and within 1 s, the closing spring pushes the iron core with valve plate back onto the valve seat. The gas solenoid valve VG closes and the gas supply is stopped. The strainer in the inlet of the gas solenoid valve prevents deposits of dirt particles on the valve seat. The pressure loss through the strainer is very low. The flow rate can be varied by a restrictor in the housing bottom.

3 Function

VG 15–40/32..M

In the version without non-ferrous metals, the solenoid valves are suitable for operation with biogas.

VG 15–65..DMVZ

The valves do not contain non-ferrous metals and a rolling diaphragm prevents dirt deposits in the guide tube.

3.2 Gas solenoid valve VG..L, slow opening

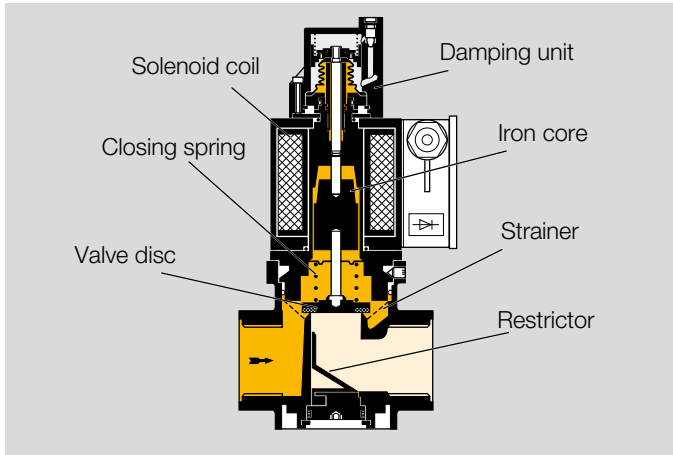

VG 15–40/32..R..L

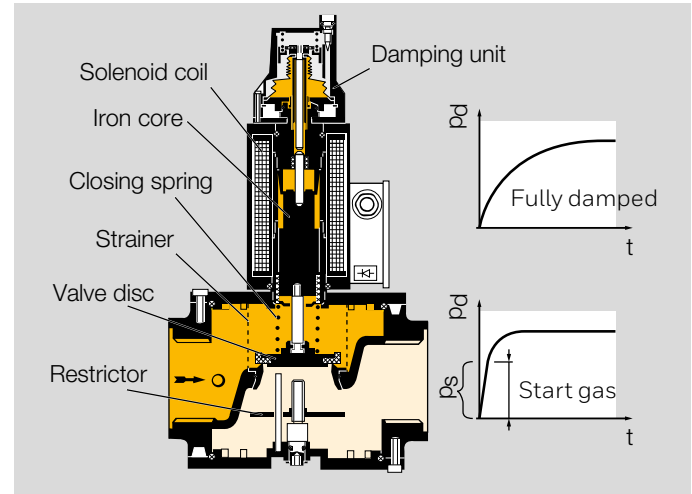

VG 40–65..R..L

The gas solenoid valve VG..L opens within 10 s.

With start gas rate: the gas solenoid valve opens with a quick initial lift and then continues slowly until it is fully open. A start gas rate is required, for example if a tightness control TC is to be used.

By turning the damping unit, the start gas rate can be set between 0 and 70% of the flow rate (at $\Delta p = 1$ mbar): Turning it clockwise will decrease the start gas rate and turning it anticlockwise will increase the start gas rate.

No start gas rate is set at the factory.

4 Flow rate

4.1 Valves for low inlet pressures, $p_{u} < 1$ bar

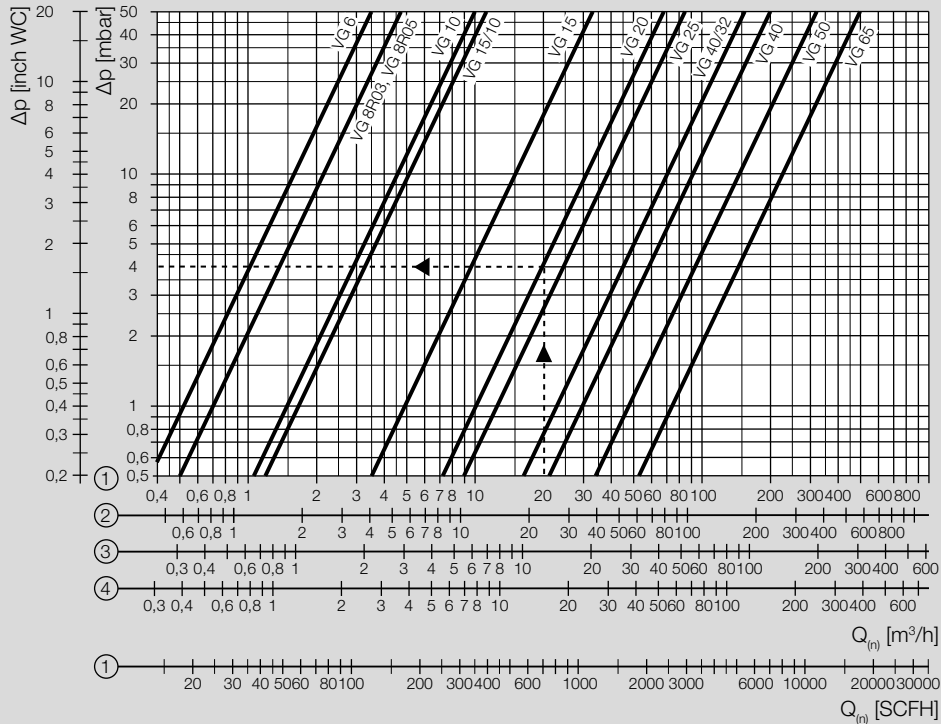

- 1 = natural gas ($\rho = 0.80 \text{ kg/m}^3$)
- 2 = propane ($\rho = 2.01 \text{ kg/m}^3$)
- 3 = hydrogen ($\rho = 0.09 \text{ kg/m}^3$)
- 4 = air ($\rho = 1.29 \text{ kg/m}^3$)

loss Δp read must be multiplied by the absolute pressure in bar (positive pressure + 1) to account for the change in the medium's density.

Reading instructions: when determining the pressure loss, operating cubic metres must be entered. Then the pressure

4 Flow rate

Example

inlet pressure p_u (positive pressure) = 200 mbar,

gas type: natural gas,

operating flow rate $Q_b = 20 \text{ m}^3/\text{h}$ (b),

Δp from diagram = 4 mbar,

$\Delta p = 4 \text{ mbar} \times (1 + 0.2) = 4.8 \text{ mbar}$ on the

solenoid valve VG 20

4.2 Valves for higher inlet pressures, $p_u > 1$ bar

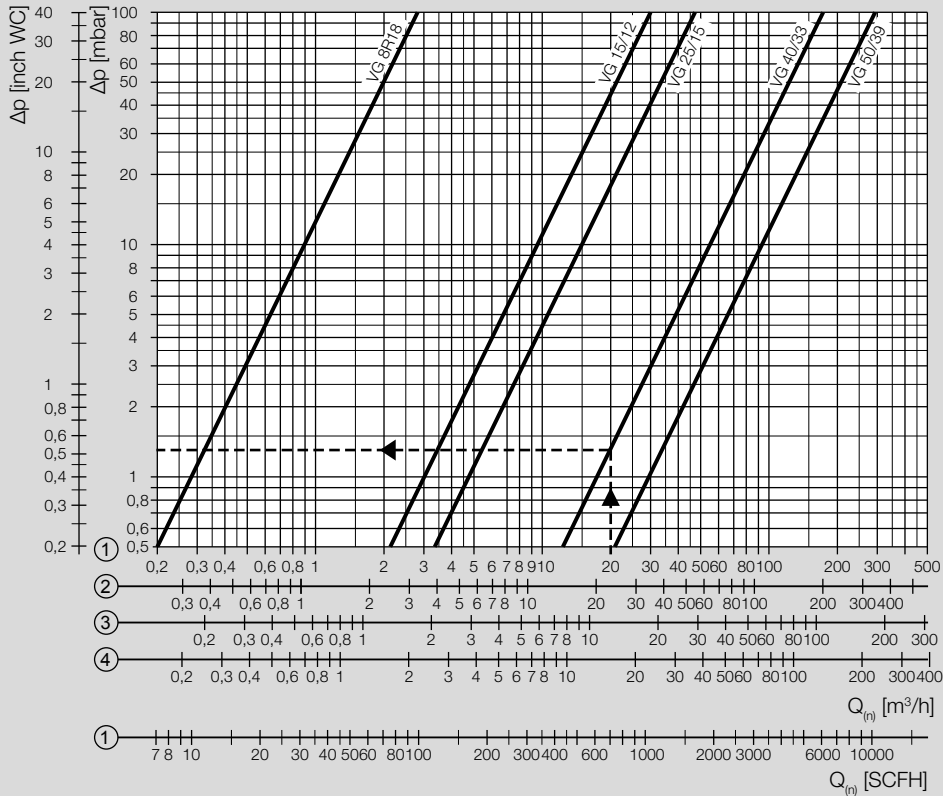

- 1 = natural gas ($\rho = 0.80 \text{ kg/m}^3$)
- 2 = propane ($\rho = 2.01 \text{ kg/m}^3$)
- 3 = hydrogen ($\rho = 0.09 \text{ kg/m}^3$)
- 4 = air ($\rho = 1.29 \text{ kg/m}^3$)

Reading instructions: when determining the pressure loss, operating cubic metres must be entered. Then the pressure loss Δp read must be multiplied by the absolute pressure in bar (positive pressure + 1) to account for the change in the medium's density.

Example

inlet pressure p_u (positive pressure) = 200 mbar,
gas type: natural gas,
operating flow rate $Q_b = 20 \text{ m}^3/\text{h}$ (b),
 Δp from diagram = 1.25 mbar,
 $\Delta p = 1.25 \text{ mbar} \times (1 + 0.2) = 1.5 \text{ mbar}$ on the
solenoid valve VG 40/33

4.3 Calculating the nominal size

A web app for calculating the nominal size is available at
www.adlatus.org.

5 Selection

5.1 ProFi

A web app selecting the correct product is available at www.adlatus.org.

5.2 VG 6–15/10

Option	VG 6K	VG 6R	VG 8	VG 10	VG 15/10
DN	6	6	8	10	15/10
Pipe connection	K	R	R	R	R
Inlet pressure	03, 05	05	03, 05, 18	01	01
Mains voltage	T, Q, K	T, Q, K	T, Q, K	T, Q, K	T, Q, K
Electrical connection	6	6	6	6	6
Low-noise	G		G		G

Order example

VG 8R03T6

5.2.1 Type code

VG	Gas solenoid valve
6–15/10	Nominal size
K	Double-cone olive for 8 mm tube loosely enclosed
R	Rp internal thread
01	p_u max. 100 mbar
03	p_u max. 360 mbar
05	p_u max. 500 mbar
18	p_u max. 1.8 bar
T	Mains voltage: 220/240 V AC, 50/60 Hz
Q	Mains voltage: 120 V AC, 50/60 Hz
K	Mains voltage: 24 V DC
6	Connection via 3-pin standard plug and socket
G	Low-noise

5.3 VG 10/15–65

Option	VG 15–25	VG 15/12, VG 25/15	VG 40	VG 40/32	VG 40/33, VG 50/39	VG 50	VG 65
DN	15, 20, 25	15/12, 25/15	40	40/32	40/33, 50/39	50	65
Pipe connection	R	R	R	R	R, F	R, F	F
Inlet pressure	02, 03	18	03	02	10	03	02
Opening properties	N, L	N	N, L	N, L	N	N, L	N, L
Mains voltage	T, Q, K	T, Q, K	T, Q, K	T, Q, K	T, Q, K	T, Q, K	T, Q, K
Electrical connection	3	3	3	3	3	3	3
Pressure measuring point	1	1	3	1	3	3	3
Flow adjustment	D		D	D		D	D
Biogas	M		M	M		M	M
Viton	V		V	V		V	V
Rolling diaphragm	Z		Z	Z		Z	Z

Order example

VG 40R03NT33DMVZ

5.3.1 Type code

VG	Solenoid valve for gas
10/15-65	Nominal size
R	Rp internal thread
F	Flange to ISO 7005
02	p_U max. 200 mbar
03	p_U max. 360 mbar
10	p_U max. 1 bar
18	p_U max. 1.8 bar
L	Slow opening, quick closing
N	Quick opening, quick closing
T	Mains voltage 220/240 V AC, 50/60 Hz
Q	Mains voltage 120 V AC, 50/60 Hz
K	Mains voltage 24 V DC
3	Terminal connection box, IP 54
1	Screw plug at the inlet
3	Screw plug at the inlet and outlet
D	With flow adjustment
M	Suitable for biogas
V	Viton valve disc seal
Z	With rolling diaphragm

6 Project planning information

6.1 Installation

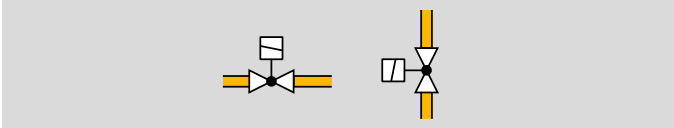

Installation position: black solenoid actuator in the vertical upright position or tilted up to the horizontal, not upside down.

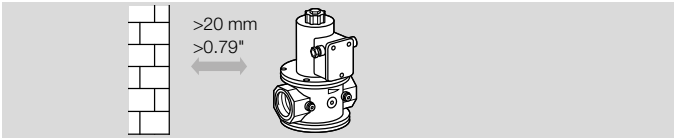

The device must not be in contact with masonry. Minimum clearance 20 mm (0.79").

Do not store or install the unit in the open air.

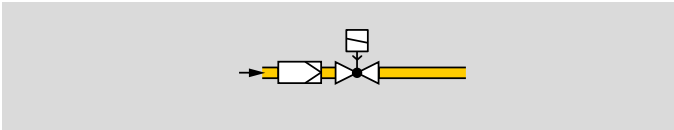

Sealing material and thread cuttings must not be allowed to get into the valve housing. Install a filter upstream of every system.

6.2 Electrical connection

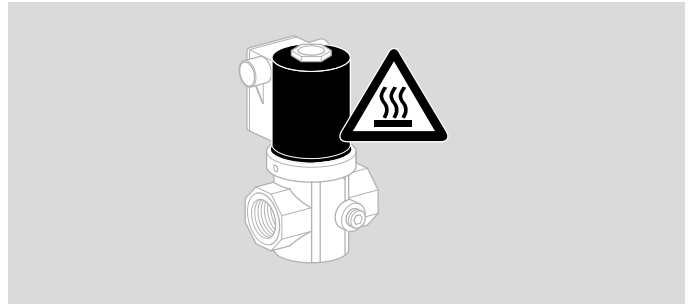

The solenoid actuator heats up during operation. Surface temperature approx. 85°C (185°F) pursuant to EN 60730-1.

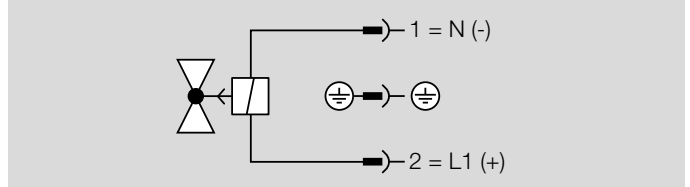

Wiring to EN 60204-1.

6.3 Hydrogen



Other hydrogen-compatible products can be found here: [Technical Information](#), [Products for hydrogen](#).

7 Accessories

7.1 Pressure test nipples

Test nipples to check the inlet pressure p_u and outlet pressure p_d .

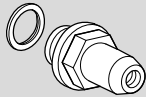

Order No.: 74912868.

Scope of delivery: 1 x G 1/4 test nipple with 1 x flat seal.

7.2 Plug with socket

Plug with socket to EN 175301-803.



Order No.	
74923085	Plug + LED VG 15-40/32 230/115V /B
74923087	Plug + LED VG 15-40/32 24V /B
74923086	Plug + LED VG 40-65 230/115V /B
74923088	Plug + LED VG 40-65 24V /B

8 Technical data

Gas types: natural gas, town gas, LPG (gaseous), biogas (max. 0.1 %-by-vol. H_2S) – VG 6–15/10 and VG..M versions only –, hydrogen or clean air; other gases on request. The gas must be dry in all temperature conditions and must not contain condensate.

Opening time:

VG..N: quick opening, 0.5 s,

VG..L: slow opening, 10 s.

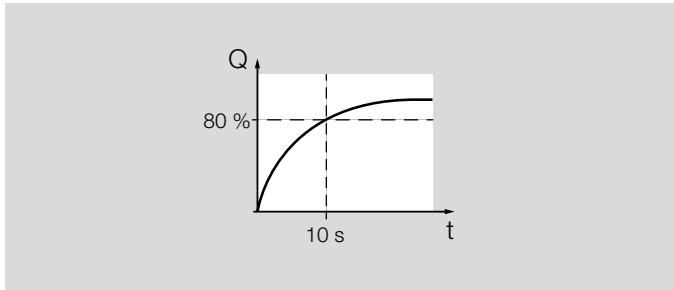

Closing time:

VG..N, VG..L: < 1 s.

Ambient temperature: -20 to +60°C, no condensation permitted.

Storage temperature: -20 to +40°C.

Safety valve: Class A, Group 2 pursuant to EN 13611 and EN 161.

Mains voltage:

220/240 V AC, +10/-15%, 50/60 Hz,

120 V AC, +10/-15%, 50/60 Hz,

24 V DC, +10/-15%.

Electrical connection of VG 6–15/10:

Plug with socket to EN 175301-803.

Electrical connection of VG 15–40/32:

Plug with socket to EN 175301-803 (available as an accessory),

cable gland: PG 11,

connection terminal: 2.5 mm².

Electrical connection of VG 40–65:

Plug with socket to EN 175301-803 (available as an accessory),

cable gland: PG 13.5,

connection terminal: 2.5 mm².

Enclosure: IP 54.

Duty cycle: 100%.

Power factor of the solenoid coil: $\cos \varphi = 1$.

Solenoid coil insulation: class F insulating material.

Switching frequency: VG..N: max. 30/min.

VG..L: there must be a period of 20 seconds between switching off and on again so that the damping is fully effective.

Valve housing: aluminium,

valve plate: NBR.

Internal thread: Rp to ISO 7-1.

Flange: ISO 7005 (DN 65 to DIN 2501), PN 16.

9 Dimensions

9.1 VG 6 to 15/10

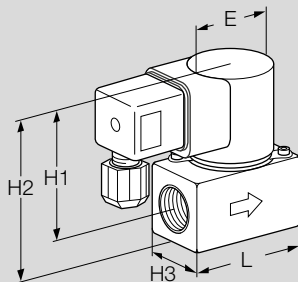

Type	Connection		Dimensions [mm]					P _{U max.} [mbar]	P [VA/W]		Weight [g]
	DN		L	H1	H2	H3	E		220 V AC 120 V AC 24 V DC	240 V AC	
VG 6K03G	6	M12 x 1	53	63	76	26	35	360	8	9.5	400
VG 6K05	6	M12x1	53	63	76	26	35	500	8	9.5	400
VG 6R05	6	Rp 1/8	53	63	76	26	35	500	8	9.5	400
VG 8R03G	8	Rp ¼	53	63	76	26	35	360	8	9.5	400
VG 8R05	8	Rp ¼	53	63	76	26	35	500	8	9.5	400
VG 8R18	8	Rp ¼	53	63	76	26	35	1800	8	9.5	400
VG 10R01	15	Rp 3/8	60	66	82	32	35	100	8	9.5	450
VG 15/10R01	15	Rp ½	71	66	82	32	35	100	8	9.5	450
VG 15/10R01G	15	Rp ½	71	66	82	32	35	100	8	9.5	450

9.2 VG 15 to 40/32

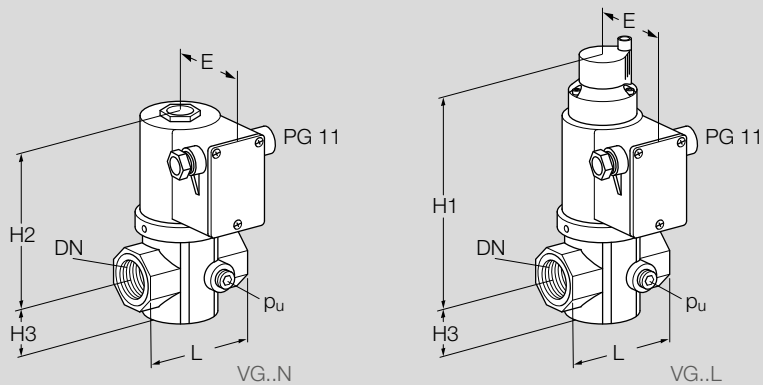

Type	Connection		Dimensions [mm]					P _u max. [mbar]	P [VA/W]		Weight [g]
	DN		L	H1	H2	H3	E		220 V AC 120 V AC 24 V DC	240 V AC	
VG 15R02..	15	Rp ½	71	161	112	24	56	200	32	38	1.26
VG 15R03..	15	Rp ½	71	161	112	24	56	360	32	38	1.26
VG 15/12R18..	15	Rp ½	71	–	112	24	61	1800	31	37	1.58
VG 20R03..	20	Rp ¾	91	175	126	33	66	360	36	42	2.25
VG 25R03..	25	Rp 1	91	175	126	33	66	360	36	42	2.25
VG 25/15R18..	25	Rp 1	91	–	126	33	66	1800	36	42	2.25
VG 40/32R02..	40	Rp 1½	128	194	145	39	66	200	36	42	2.80

9.3 VG 40 to 65

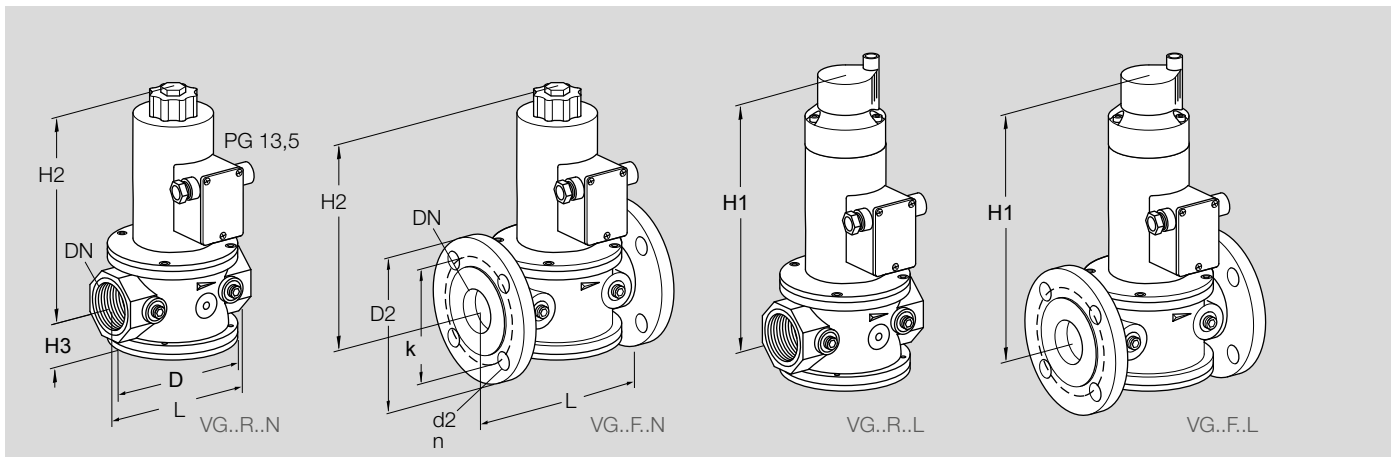

Type	Connection		Dimensions [mm]								n	P _{u max.} [mbar]	P [VA/W]		Weight [g]
	DN		L	D	H1	H2	H3	D2	k	d2			220 V AC 120 V AC 24 V DC	240 V AC	
VG 40R03..	40	Rp 1½	150	129	280	210	51	–	–	–	–	200	73	86	7.1
VG 40/33R10..	40	Rp 1½	150	129	280	210	51	–	–	–	–	1000	73	86	7.1
VG 40/33F10..	40	40	200	129	280	210	51	150	110	18	4	1000	73	86	8.8
VG 50R03..	50	Rp 2	180	157	291	221	62	–	–	–	–	360	85	99	12.8
VG 50F03..	50	50	230	157	291	221	62	165	125	18	4	360	85	99	14.8
VG 50/39R10..	50	Rp 2	180	157	–	221	62	–	–	–	–	1000	85	99	12.8
VG 50/39F10..	50	50	230	157	–	233	62	165	125	18	4	1000	85	99	14.8
VG 65F02..	65	65	290	183	303	233	74	185	145	18	4	200	85	99	16.3

10 Converting units

See www.adlatus.org

11 Maintenance cycles

At least once a year, at least twice a year in the case of biologically produced methane.

For more information

The Honeywell Thermal Solutions family of products includes Honeywell Combustion Safety, Eclipse, Exothermics, Hauck, Kromschroder and Maxon. To learn more about our products, visit ThermalSolutions.honeywell.com or contact your Honeywell Sales Engineer.

Elster GmbH
Strotheweg 1, D-49504 Lotte
T +49 541 1214-0
hts.lotte@honeywell.com
www.kromschroeder.com

© 2023 Elster GmbH

We reserve the right to make technical modifications in the interests of progress.

